

GEAFOL Cast-Resin Transformers 100 to 16000 kVA

Cast-Resin Transformers

Catalog TV1 · 2007

Power Transmission and Distribution

SIEMENS

Application

Safe technology

Wherever distribution transformers have to assure the utmost safety in areas frequented by people, GEA FOL cast-resin transformers are the ideal solution. With GEA FOL, the limitations of liquid-filled transformers are avoided, but the proven characteristics such as operational reliability and service life are retained.

Not for nothing are GEA FOL cast-resin transformers used, above all, wherever there can be no compromises with regard to safety. They are to be found in high-rise buildings, hospitals, road and underground railway shafts, in offshore installations and mines and many other locations.

It is not surprising that the superior GEA FOL technology is produced under licence by many transformer manufacturers all over the world. Over 85,000 GEA FOL cast-resin transformers have proved their worth in power distribution all round the globe.

The diagram below shows the power rating and voltage range developments achieved since 1966 as a result of continuous innovation.

Nowadays, GEA FOL cast-resin transformers up to a power rating of approximately 40 MVA are being manufactured.

Development of voltage and power ratings:

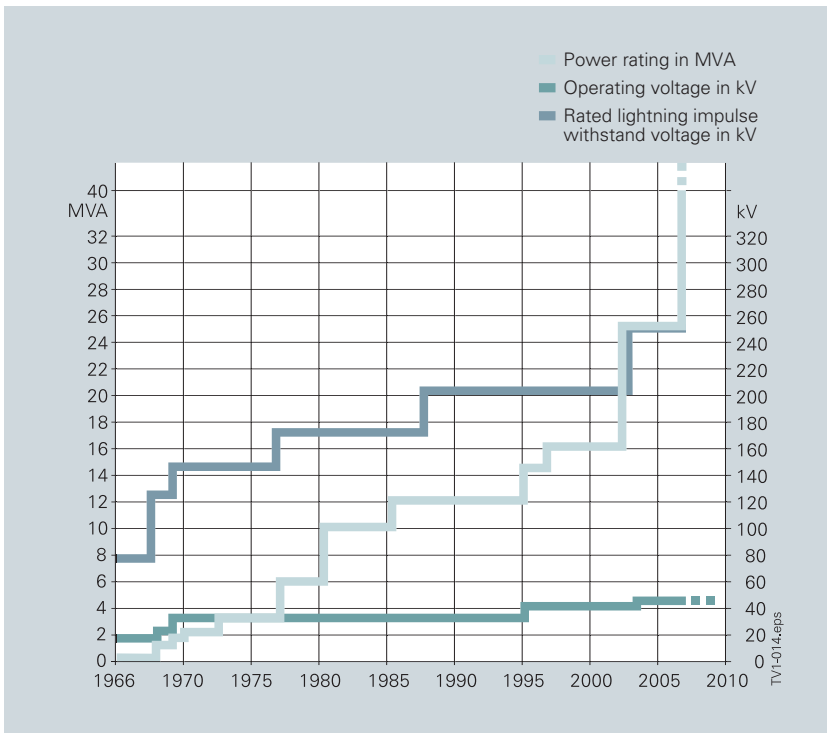

Contents

Page

Application	3
Design, Features	4
Selection and Ordering Data	5 to 9
Connection System	10
Temperature Supervision	11
Forced-Air Cooling	11
Standard Housings	12
Selection of Housings	13
Special Housing, Notes, Dimensions	14

Supersedes: Catalog TV 1 · 2004



The products and systems described in this catalog are manufactured and sold according to a certified quality and environmental management system (acc. to ISO 9001:2000 and ISO 14001:2004). (DQS Certificate Reg. No. DQS 001052 QM UM). The certificate is accepted in all IQNet countries.

© Siemens AG 2007

Design, Features

① Three-limb core

Made of grain-oriented, low-loss electrolaminations insulated on both sides

② LV winding

Made of aluminium strip. Turns firmly glued together by means of insulating sheet wrapper material

③ HV winding

Consisting of vacuum-potted single foil-type aluminium coils

④ LV connection

Normal arrangement: Top, rear
Special version: Bottom, available on request at extra charge

⑤ HV connection

Variable arrangement, for optimal station design

HV tapings on high-voltage connection side

For adjustment to system conditions, reconnectable in deenergized state

⑥ Coil support system

To insulate core and windings from mechanical vibrations, resulting in low noise emissions

⑦ Clamping frame and truck

Rollers can be turned around for lengthwise or sidewise travel

⑧ Insulation: Mixture of epoxy resin and quartz powder

Makes the transformer practically maintenance-free, moisture-proof, tropicalized, flame-resistant and self-extinguishing, without using aluminium oxide trihydrate

⑨ Connection tubes



Temperature monitoring

By PTC thermistor sensors in the LV winding (on request PT 100)

Paint finish on steel parts

Thick-layer coating, RAL 5009

On request:

Two-component varnish or galvanizing (for particularly aggressive environments)

Modular design

E.g. windings can be individually mounted and replaced on site

Ambient class E2

Climatic category C2

(if the transformer is installed outdoors, degree of protection IP23 must be assured)

Fire class F1

630 kVA GEAFOLE
cast-resin transformer,
 $U_f = 20$ kV

Selection and Ordering Data

Distribution transformers according to HD 538, 50 Hz, Dyn 5 or Dyn 11, IP00 without housing (housings IP.., see page 12).

All GEA FOL cast-resin transformers according to IEC 60076-11, rated power > 2500 kVA are not standardized.

Other versions and special equipment on request.

Rated power	Rated primary voltage tapping $\pm 2 \times 2.5\%$		Rated secondary voltage (no-load)	Insulation level HV (AC(LI))	Insulation level LV (AC(LI))	Impedance voltage at rated current	No-load losses	Load losses at rated current	Noise level	Order No.	Total weight	Length	Width	Height
S_r kVA	U_r HV kV	U_r LV kV	kV	kV	u_{zr} %	P_o W	P_{k120} W	L_{WA} dB			approx. kg	a ²⁾ mm	b ²⁾ mm	h ²⁾ mm
100	10	0.4	28/75	3/-	4	440	1850	59		4GB5044-3CA05-0AA2	600	1210	670	840
	10	0.4	28/75	3/-	4	320	1850	51		4GB5044-3GA05-0AA2	720	1230	675	845
	10	0.4	28/75	3/-	6	360	2000	59		4GB5044-3DA05-0AA2	570	1200	680	805
	10	0.4	28/75	3/-	6	290	2000	51		4GB5044-3HA05-0AA2	720	1280	685	890
	20	0.4	50/95	3/-	4	600	1750	59		4GB5064-3CA05-0AA2	620	1220	740	925
	20	0.4	50/95	3/-	4	400	1750	51		4GB5064-3GA05-0AA2	740	1260	745	945
	20	0.4	50/95	3/-	6	460	2050	59		4GB5064-3DA05-0AA2	610	1250	750	915
	20	0.4	50/95	3/-	6	340	2050	51		4GB5064-3HA05-0AA2	730	1280	750	940
	20	0.4	50/125	3/-	6	460	2050	59		4GB5067-3DA05-0AA2	720	1260	750	1145
160	10	0.4	28/75	3/-	4	610	2600	62		4GB5244-3CA05-0AA2	820	1270	690	1025
	10	0.4	28/75	3/-	4	440	2600	54		4GB5244-3GA05-0AA2	960	1260	685	1100
	10	0.4	28/75	3/-	6	500	2750	62		4GB5244-3DA05-0AA2	690	1220	685	990
	10	0.4	28/75	3/-	6	400	2750	54		4GB5244-3HA05-0AA2	850	1290	695	1010
	20	0.4	50/95	3/-	4	870	2500	62		4GB5264-3CA05-0AA2	790	1280	745	1060
	20	0.4	50/95	3/-	4	580	2500	54		4GB5264-3GA05-0AA2	920	1320	755	1060
	20	0.4	50/95	3/-	6	650	2700	62		4GB5264-3DA05-0AA2	780	1320	760	1040
	20	0.4	50/95	3/-	6	480	2700	54		4GB5264-3HA05-0AA2	860	1350	765	1050
	20	0.4	50/125	3/-	6	650	2900	62		4GB5267-3DA05-0AA2	870	1310	720	1200
250	10	0.4	28/75	3/-	4	820	3200	65		4GB5444-3CA05-0AA2	1010	1330	700	1055
	10	0.4	28/75	3/-	4	600	3200	57		4GB5444-3GA05-0AA2	1250	1340	700	1190
	10	0.4	28/75	3/-	6	700	3300	65		4GB5444-3DA05-0AA2	960	1340	705	1055
	10	0.4	28/75	3/-	6	560	3300	57		4GB5444-3HA05-0AA2	1130	1390	715	1070
	20	0.4	50/95	3/-	4	1100	3200	65		4GB5464-3CA05-0AA2	1070	1370	730	1115
	20	0.4	50/95	3/-	4	800	3300	57		4GB5464-3GA05-0AA2	1230	1420	740	1130
	20	0.4	50/95	3/-	6	880	3400	65		4GB5464-3DA05-0AA2	1020	1390	740	1105
	20	0.4	50/95	3/-	6	650	3400	57		4GB5464-3HA05-0AA2	1190	1430	745	1125
	20	0.4	50/125	3/-	6	880	3800	65		4GB5467-3DA05-0AA2	1070	1390	740	1200
	30	0.4	70/145	3/-	6	1280	4000	67		4GB5475-3DA05-0AA2	1190	1450	825	1365
(315)¹⁾	10	0.4	28/75	3/-	4	980	3500	67		4GB5544-3CA05-0AA2	1120	1340	820	1130
	10	0.4	28/75	3/-	4	730	3500	59		4GB5544-3GA05-0AA2	1400	1400	820	1195
	10	0.4	28/75	3/-	6	850	3900	67		4GB5544-3DA05-0AA2	1130	1360	820	1160
	10	0.4	28/75	3/-	6	670	3700	59		4GB5544-3HA05-0AA2	1260	1400	820	1170
	20	0.4	50/95	3/-	4	1250	3500	67		4GB5564-3CA05-0AA2	1370	1490	835	1145
	20	0.4	50/95	3/-	4	930	3500	59		4GB5564-3GA05-0AA2	1590	1520	835	1205
	20	0.4	50/95	3/-	6	1000	3800	67		4GB5564-3DA05-0AA2	1350	1490	835	1180
	20	0.4	50/95	3/-	6	780	3800	59		4GB5564-3HA05-0AA2	1450	1520	840	1205
	20	0.4	50/125	3/-	6	1000	4200	67		4GB5567-3DA05-0AA2	1430	1520	840	1235
	30	0.4	70/145	3/-	6	1450	4700	69		4GB5575-3DA05-0AA2	1460	1510	915	1445

1) Ratings in brackets are not standardized.

2) Dimension drawing: page 14.

Selection and Ordering Data

Distribution transformers according to HD 538, 50 Hz, Dyn 5 or Dyn 11, IP00 without housing (housings IP..., see page 12).

All GEAFOL cast-resin transformers according to IEC 60076-11, rated power > 2500 kVA are not standardized.

Other versions and special equipment on request.

Rated power	Rated primary voltage tapping $\pm 2 \times 2.5\%$		Rated secondary voltage (No-load)	Insulation level HV (AC(LI))	Insulation level LV (AC(LI))	Impedance voltage at rated current	No-load losses	Load losses at 120 °C	Noise level	Order No.	Total weight	Length	Width	Height
S_r kVA	U_r HV kV	U_r LV kV	kV	kV	u_{zr} %	P_o W	P_{k120} W	L_{WA} dB			approx. kg	a ²⁾ mm	b ²⁾ mm	h ²⁾ mm
400	10	0.4	28/75	3/-	4	1150	4400	68		4GB5644-3CA05-0AA2	1290	1370	820	1230
	10	0.4	28/75	3/-	4	880	4400	60		4GB5644-3GA05-0AA2	1500	1390	820	1330
	10	0.4	28/75	3/-	6	1000	4900	68		4GB5644-3DA05-0AA2	1230	1400	820	1215
	10	0.4	28/75	3/-	6	800	4900	60		4GB5644-3HA05-0AA2	1390	1430	820	1230
	20	0.4	50/95	3/-	4	1450	3800	68		4GB5664-3CA05-0AA2	1470	1460	830	1285
	20	0.4	50/95	3/-	4	1100	3800	60		4GB5664-3GA05-0AA2	1710	1520	835	1305
	20	0.4	50/95	3/-	6	1200	4300	68		4GB5664-3DA05-0AA2	1380	1490	835	1260
	20	0.4	50/95	3/-	6	940	4300	60		4GB5664-3HA05-0AA2	1460	1500	840	1260
	20	0.4	50/125	3/-	6	1200	4700	68		4GB5667-3DA05-0AA2	1530	1540	845	1310
(500)¹⁾	10	0.4	28/75	3/-	4	1300	5900	69		4GB5744-3CA05-0AA0	1490	1410	820	1315
	10	0.4	28/75	3/-	4	1000	5300	61		4GB5744-3GA05-0AA0	1620	1420	820	1340
	10	0.4	28/75	3/-	6	1200	6400	69		4GB5744-3DA05-0AA0	1420	1450	820	1245
	10	0.4	28/75	3/-	6	950	6400	61		4GB5744-3HA05-0AA0	1540	1490	820	1265
	20	0.4	50/95	3/-	4	1700	4900	69		4GB5764-3CA05-0AA0	1550	1460	840	1365
	20	0.4	50/95	3/-	4	1300	4900	61		4GB5764-3GA05-0AA0	1700	1490	845	1370
	20	0.4	50/95	3/-	6	1400	5100	69		4GB5764-3DA05-0AA0	1500	1530	855	1275
	20	0.4	50/95	3/-	6	1100	5100	61		4GB5764-3HA05-0AA0	1670	1560	860	1290
	20	0.4	50/125	3/-	6	1400	6300	69		4GB5767-3DA05-0AA0	1610	1540	855	1355
	30	0.4	70/145	3/-	6	1900	6000	70		4GB5775-3DA05-0AA0	1810	1560	925	1615
630	10	0.4	28/75	3/-	4	1500	7300	70		4GB5844-3CA05-0AA0	1670	1410	820	1485
	10	0.4	28/75	3/-	4	1150	7300	62		4GB5844-3GA05-0AA0	1840	1440	820	1485
	10	0.4	28/75	3/-	6	1370	7500	70		4GB5844-3DA05-0AA0	1710	1520	830	1305
	10	0.4	28/75	3/-	6	1100	7500	62		4GB5844-3HA05-0AA0	1850	1560	835	1330
	20	0.4	50/95	3/-	4	2000	6900	70		4GB5864-3CA05-0AA0	1790	1470	840	1530
	20	0.4	50/95	3/-	4	1600	6900	62		4GB5864-3GA05-0AA0	1930	1520	845	1565
	20	0.4	50/95	3/-	6	1650	6800	70		4GB5864-3DA05-0AA0	1750	1560	860	1365
	20	0.4	50/95	3/-	6	1250	6800	62		4GB5864-3HA05-0AA0	1900	1600	865	1385
	20	0.4	50/125	3/-	6	1650	7000	70		4GB5867-3DA05-0AA0	1830	1590	865	1395
(800)¹⁾	10	0.4	28/75	3/-	4	1800	7800	72		4GB5944-3CA05-0AA0	1970	1500	820	1535
	10	0.4	28/75	3/-	4	1400	7800	64		4GB5944-3GA05-0AA0	2210	1530	825	1535
	10	0.4	28/75	3/-	6	1700	8300	72		4GB5944-3DA05-0AA0	2020	1590	840	1395
	10	0.4	28/75	3/-	6	1300	8300	64		4GB5944-3HA05-0AA0	2230	1620	845	1395
	20	0.4	50/95	3/-	4	2400	8500	72		4GB5964-3CA05-0AA0	2020	1550	850	1595
	20	0.4	50/95	3/-	4	1900	8500	64		4GB5964-3GA05-0AA0	2220	1570	855	1595
	20	0.4	50/95	3/-	6	1900	8200	72		4GB5964-3DA05-0AA0	2020	1610	870	1435
	20	0.4	50/95	3/-	6	1500	8200	64		4GB5964-3HA05-0AA0	2220	1650	875	1455
	20	0.4	50/125	3/-	6	1900	9400	72		4GB5967-3DA05-0AA0	2160	1660	880	1485
	30	0.4	70/145	3/-	6	2650	7900	72		4GB5975-3DA05-0AA0	2620	1740	965	1695

1) Ratings in brackets are not standardized.

2) Dimension drawing: page 14.

Selection and Ordering Data

Distribution transformers according to HD 538, 50 Hz, Dyn 5 or Dyn 11, IP00 without housing (housings IP.., see page 12).

All GEA FOL cast-resin transformers according to IEC 60076-11, rated power > 2500 kVA are not standardized.

Other versions and special equipment on request.

Rated power	Rated primary voltage tapping $\pm 2 \times 2.5\%$		Rated secondary voltage (no-load)	Insulation level HV (AC(LI))	Insulation level LV (AC(LI))	Impedance voltage at rated current	No-load losses	Load losses at 120 °C	Noise level	Order No.	Total weight	Length	Width	Height
S_r kVA	U_r HV kV	U_r LV kV	kV	kV	u_{zr} %	P_o W	P_{k120} W	L_{WA} dB			approx. kg	a ²⁾ mm	b ²⁾ mm	h ²⁾ mm
1000	10	0.4	28/75	3/-	4	2100	10000	73		4GB6044-3CA05-0AA0	2440	1550	990	1730
	10	0.4	28/75	3/-	4	1600	10000	65		4GB6044-3GA05-0AA0	2850	1620	990	1795
	10	0.4	28/75	3/-	6	2000	9500	73		4GB6044-3DA05-0AA0	2370	1640	990	1490
	10	0.4	28/75	3/-	6	1500	9500	65		4GB6044-3HA05-0AA0	2840	1710	990	1565
	20	0.4	50/95	3/-	4	2800	9500	73		4GB6064-3CA05-0AA0	2420	1570	990	1790
	20	0.4	50/95	3/-	4	2300	8700	65		4GB6064-3GA05-0AA0	2740	1680	990	1665
	20	0.4	50/95	3/-	6	2300	9000	73		4GB6064-3DA05-0AA0	2310	1640	990	1620
	20	0.4	50/95	3/-	6	1800	9000	65		4GB6064-3HA05-0AA0	2510	1660	990	1620
	20	0.4	50/125	3/-	6	2300	11000	73		4GB6067-3DA05-0AA0	2470	1670	990	1650
	30	0.4	70/145	3/-	6	3100	10000	73		4GB6075-3DA05-0AA0	2990	1800	1060	1795
(1250)¹⁾	10	0.4	28/75	3/-	6	2400	11000	75		4GB6144-3DA05-0AA0	2780	1740	990	1635
	10	0.4	28/75	3/-	6	1800	11000	67		4GB6144-3HA05-0AA0	3140	1770	990	1675
	20	0.4	50/95	3/-	6	2700	11200	75		4GB6164-3DA05-0AA0	2740	1780	990	1645
	20	0.4	50/95	3/-	6	2100	11200	67		4GB6164-3HA05-0AA0	3010	1810	990	1645
	20	0.4	50/125	3/-	6	2700	10500	75		4GB6167-3DA05-0AA0	2980	1810	990	1675
	30	0.4	70/145	3/-	6	3600	11500	75		4GB6175-3DA05-0AA0	3580	1870	1065	1895
1600	10	0.4	28/75	3/-	6	2800	14000	76		4GB6244-3DA05-0AA0	3490	1830	990	1735
	10	0.4	28/75	3/-	6	2100	14000	68		4GB6244-3HA05-0AA0	4130	1880	990	1775
	20	0.4	50/95	3/-	6	3100	13500	76		4GB6264-3DA05-0AA0	3440	1840	995	1830
	20	0.4	50/95	3/-	6	2400	13500	68		4GB6264-3HA05-0AA0	3830	1870	1000	1880
	20	0.4	50/125	3/-	6	3100	12500	76		4GB6267-3DA05-0AA0	3690	1860	995	1880
	30	0.4	70/145	3/-	6	4100	13500	76		4GB6275-3DA05-0AA0	4350	1970	1090	1995
(2000)¹⁾	10	0.4	28/75	3/-	6	3500	15700	78		4GB6344-3DA05-0AA0	4150	1940	1280	1935
	10	0.4	28/75	3/-	6	2600	15700	70		4GB6344-3HA05-0AA0	4890	1970	1280	2015
	20	0.4	50/95	3/-	6	4000	15400	78		4GB6364-3DA05-0AA0	4170	1980	1280	1960
	20	0.4	50/95	3/-	6	2900	15400	70		4GB6364-3HA05-0AA0	4720	2010	1280	1985
	20	0.4	50/125	3/-	6	4000	15500	78		4GB6367-3DA05-0AA0	4430	2020	1280	2005
	30	0.4	70/145	3/-	6	5000	15000	78		4GB6375-3DA05-0AG0	5090	2100	1280	2135
2500	10	0.4	28/75	3/-	6	4300	18700	81		4GB6444-3DA05-0AG0	4840	2090	1280	2070
	10	0.4	28/75	3/-	6	3000	18700	71		4GB6444-3HA05-0AA0	5940	2160	1280	2135
	20	0.4	50/95	3/-	6	5000	18000	81		4GB6464-3DA05-0AA0	5200	2150	1280	2165
	20	0.4	50/95	3/-	6	3600	19000	71		4GB6464-3HA05-0AA0	6020	2190	1280	2180
	20	0.4	50/125	3/-	6	5000	18000	81		4GB6467-3DA05-0AG0	5020	2160	1280	2105
	30	0.4	70/145	3/-	6	5800	20000	81		4GB6475-3DA05-0AG0	5920	2280	1280	2215
3150	10	0.4	28/75	3/-	6	5400	25000	82		4GB6544-3DA05-0AA0	6500	2450	1280	2310
	10	0.69	28/75	3/-	6	5400	18000	81		4GB6544-8DA05-0AA0	6480	2200	1280	2055
	10	3.3	28/75	10/20	6	5400	18000	81		4GB6544-9DA05-0AA0 H1N	6470	2230	1280	2000
	20	0.4	50/95	3/-	6	6000	24000	81		4GB6564-3DA05-0AG0	6170	2320	1280	2230
	20	0.69	50/95	3/-	6	6200	18000	81		4GB6564-8DA05-0AG0	6080	2170	1280	2105
	20	3.3	50/95	10/20	6	6200	18000	81		4GB6564-9DA05-0AA0 H1N	6660	2280	1280	2030
	20	0.4	50/125	3/-	6	6200	21000	81		4GB6567-3DA05-0AG0	6290	2340	1280	2300
	20	0.69	50/125	3/-	6	6200	18000	81		4GB6567-8DA05-0AG0	6170	2170	1280	2150
20	3.3	50/125	10/20	6	7300	18000	81		4GB6567-9DA05-0AA0 H1N	6770	2300	1280	2060	

1) Ratings in brackets are not standardized.

2) Dimension drawing: page 14.

Selection and Ordering Data

Distribution transformers according to HD 538, 50 Hz, Dyn 5 or Dyn 11, IP00 without housing (housings IP..., see page 12).

All GEAFOL cast-resin transformers according to IEC 60076-11, rated power > 2500 kVA are not standardized.

Other versions and special equipment on request.

Rated power	Rated primary voltage tapping $\pm 2 \times 2.5\%$		Rated secondary voltage (no-load)	Insulation level HV (AC(LI))	Insulation level LV (AC(LI))	Impedance voltage at rated current	No-load losses	Load losses at 120 °C	Noise level	Order No.	Total weight	Length	Width	Height
S_r kVA	U_r HV kV	U_r LV kV	kV	kV	u_{Zr} %	P_o W	P_{k120} W	L_{WA} dB			approx. kg	a ¹⁾ mm	b ¹⁾ mm	h ¹⁾ mm
4000	10	0.69	28/75	3/-	6	6300	20000	81		4GB6644-8DA05-0AG0	7970	2360	1280	2245
	10	3.3	28/75	10/20	6	6300	19000	81		4GB6644-9DA05-0AA0 H1N	8570	2450	1280	2080
	10	6.3	28/75	20/40	6	6300	19000	76		4GB6644-9DA05-0AA0 H2B	9210	2570	1280	2125
	20	0.69	50/95	3/-	6	7600	21000	83		4GB6664-8DA05-0AG0	7330	2280	1280	2330
	20	3.3	50/95	10/20	6	7600	19000	83		4GB6664-9DA05-0AG0 H1N	7450	2460	1280	2050
	20	6.3	50/95	20/40	6	7600	19000	83		4GB6664-9DA05-0AA0 H2B	8710	2590	1280	2055
	20	0.69	50/125	3/-	6	7600	21000	85		4GB6667-8DA05-0AG0	7430	2400	1280	2335
	20	3.3	50/125	10/20	6	7600	19000	83		4GB6667-9DA05-0AG0 H1N	7850	2430	1280	2100
5000	10	3.3	28/75	10/20	6	7600	21000	81		4GB6744-9DA05-0AG0 H1N	9620	2480	1280	2290
	10	6.3	28/75	20/40	6	7600	23000	78		4GB6744-9DA05-0AA0 H2B	10370	2590	1400	2290
	10	3.3	28/75	10/20	8	7600	23000	76		4GB6744-9KA05-0AG0 H1N	9680	2600	1280	2250
	10	6.3	28/75	20/40	8	7600	24000	78		4GB6744-9KA05-0AA0 H2B	10490	2690	1400	2290
	20	3.3	50/95	10/20	6	9000	21000	83		4GB6764-9DA05-0AG0 H1N	9090	2530	1280	2210
	20	6.3	50/95	20/40	6	9000	23000	83		4GB6764-9DA05-0AG0 H2B	9650	2600	1280	2295
	20	3.3	50/125	10/20	6	9000	21000	83		4GB6767-9DA05-0AG0 H1N	9400	2530	1280	2280
	20	6.3	50/125	20/40	6	9000	22000	83		4GB6767-9DA05-0AA0 H2B	9980	2640	1285	2365
	20	3.3	50/95	10/20	8	9000	23000	83		4GB6764-9KA05-0AG0 H1N	9090	2600	1280	2210
	20	6.3	50/95	20/40	8	9000	24000	83		4GB6764-9KA05-0AG0 H2B	9750	2710	1295	2295
	20	3.3	50/125	10/20	8	9000	23000	83		4GB6767-9KA05-0AG0 H1N	9090	2610	1280	2240
	20	6.3	50/125	20/40	8	9000	24000	83		4GB6767-9KA05-0AA0 H2B	10330	2720	1400	2290
6300	10	3.3	28/75	10/20	6	9200	26000	76		4GB6844-9DA05-0AG0 H1N	11960	2570	1905	2650
	10	6.3	28/75	20/40	6	9200	27000	83		4GB6844-9DA05-0AG0 H2B	12240	2650	1905	2630
	10	3.3	28/75	10/20	8	9200	26000	78		4GB6844-9KA05-0AG0 H1N	11670	2630	1905	2610
	10	6.3	28/75	20/40	8	9200	28000	83		4GB6844-9KA05-0AG0 H2B	12240	2730	1905	2630
	20	3.3	50/95	10/20	6	10800	24000	83		4GB6864-9DA05-0AG0 H1N	11740	2640	1905	2440
	20	6.3	50/95	20/40	6	10800	26000	83		4GB6864-9DA05-0AG0 H2B	12120	2700	1905	2540
	20	3.3	50/125	10/20	6	10800	24000	83		4GB6867-9DA05-0AG0 H1N	11780	2640	1905	2470
	20	6.3	50/125	20/40	6	10500	26000	84		4GB6867-9DA05-0AG0 H2B	12140	2700	1905	2560
	20	3.3	50/95	10/20	8	10800	26000	83		4GB6864-9KA05-0AG0 H1N	11850	2780	1905	2440
	20	6.3	50/95	20/40	8	10800	27000	84		4GB6864-9KA05-0AG0 H2B	12330	2840	1905	2545
	20	3.3	50/125	10/20	8	10500	25500	83		4GB6867-9KA05-0AG0 H1N	11890	2770	1905	2470
	20	6.3	50/125	20/40	8	10500	27000	84		4GB6867-9KA05-0AG0 H2B	12290	2820	1905	2560
8000	20	6.3	50/95	20/40	6	13000	32000	85		4GB6964-9DA05-0AG0 H2B	14290	2840	1905	2720
	20	11	50/95	28/60	6	13000	32000	85		4GB6964-9DA05-0AG0 H2T	15610	2950	1905	2790
	20	6.3	50/125	20/40	6	13000	32000	85		4GB6967-9DA05-0AG0 H2B	14540	2900	1905	2750
	20	11	50/125	28/60	6	13000	32000	85		4GB6967-9DA05-0AG0 H2T	15810	2960	1905	2820
	20	6.3	50/95	20/40	8	13000	34000	85		4GB6964-9KA05-0AG0 H2B	14360	2970	1905	2720
	20	11	50/95	28/60	8	13000	34000	85		4GB6964-9KA05-0AG0 H2T	15600	3070	1905	2790
	20	6.3	50/125	20/40	8	13000	34000	85		4GB6967-9KA05-0AG0 H2B	14370	2940	1905	2750
	20	11	50/125	28/60	8	13000	34000	85		4GB6967-9KA05-0AG0 H2T	15680	3080	1905	2820
	30	6.3	70/145	20/40	6	13500	36000	84		4GB6975-9DA05-0AG0 H2B	16230	2890	1905	3290
	30	11	70/145	28/60	6	13500	38000	84		4GB6975-9DA05-0AG0 H2T	17670	3040	1905	3260

1) Dimension drawing: page 14.

Selection and Ordering Data

Distribution transformers according to HD 538, 50 Hz, Dyn 5 or Dyn 11, IP00 without housing (housings IP.., see page 12).

All GEA FOL cast-resin transformers according to IEC 60076-11, rated power > 2500 kVA are not standardized.

Other versions and special equipment on request.

Rated power	Rated primary voltage tapping $\pm 2 \times 2.5\%$	Rated secondary voltage (no-load)	Insulation level HV (AC(LI))	Insulation level LV (AC(LI))	Impedance voltage at rated current	No-load losses	Load losses at rated current	Noise level	Order No.	Total weight	Length	Width	Height
S_r kVA	U_r HV kV	U_r LV kV	kV	kV	u_{Zr} %	P_o W	P_{k120} W	L_{WA} dB		approx. kg	a ¹⁾ mm	b ¹⁾ mm	h ¹⁾ mm
10000	20	6.3	50/95	20/40	6	15200	36000	85	4GB7064-9DA05-0AG0 H2B	17280	3020	1905	2900
	20	11	50/95	28/60	6	15200	36000	85	4GB7064-9DA05-0AG0 H2T	18130	3180	1905	2830
	20	6.3	50/125	20/40	6	15200	38000	85	4GB7067-9DA05-0AG0 H2B	17650	3080	1905	2970
	20	11	50/125	28/60	6	15200	38000	85	4GB7067-9DA05-0AG0 H2T	18760	3230	1905	2900
	20	6.3	50/95	20/40	8	15200	36000	85	4GB7064-9KA05-0AG0 H2B	17280	3140	1905	2900
	20	11	50/95	28/60	8	15200	36000	85	4GB7064-9KA05-0AG0 H2T	17660	3265	1905	2790
	20	6.3	50/125	20/40	8	15200	38000	85	4GB7067-9KA05-0AG0 H2B	17410	3130	1905	2930
	20	11	50/125	28/60	8	15200	38000	85	4GB7067-9KA05-0AG0 H2T	17740	3270	1905	2820
	30	6.3	70/145	20/40	6	15600	39000	85	4GB7075-9DA05-0AG0 H2B	19390	3090	1905	3460
	30	11	70/145	28/60	6	15600	42000	85	4GB7075-9DA05-0AG0 H2T	20890	3270	1905	3450
12500	20	6.3	50/95	20/40	6	18200	42000	85	4GB7164-9DA05-0AG0 H2B	21450	3205	1905	3100
	20	11	50/95	28/60	6	18200	44000	85	4GB7164-9DA05-0AG0 H2T	22340	3325	1905	3130
	20	6.3	50/125	20/40	6	18200	42000	85	4GB7167-9DA05-0AG0 H2B	21670	3235	1905	3130
	20	11	50/125	28/60	6	18200	44000	85	4GB7167-9DA05-0AG0 H2T	23010	3355	1905	3160
	20	6.3	50/95	20/40	8	18200	44000	85	4GB7164-9KA05-0AG0 H2B	21280	3330	1905	3060
	20	11	50/95	28/60	8	18200	46000	85	4GB7164-9KA05-0AG0 H2T	22930	3480	1905	3130
	20	6.3	50/125	20/40	8	18200	44000	85	4GB7167-9KA05-0AG0 H2B	21450	3350	1905	3090
	20	11	50/125	28/60	8	18200	46000	85	4GB7167-9KA05-0AG0 H2T	23290	3500	1905	3160
	30	6.3	70/145	20/40	6	18500	46000	85	4GB7175-9DA05-0AG0 H2B	24120	3250	1905	3580
	30	11	70/145	28/60	6	18500	48000	85	4GB7175-9DA05-0AG0 H2T	25030	3390	1905	3610
16000	20	6.3	50/95	20/40	6	22000	53000	88	4GB7264-9DA05-0AG0 H2B	26440	3190	1905	3980
	20	11	50/95	28/60	6	22000	53000	88	4GB7264-9DA05-0AG0 H2T	26380	3310	1905	3700
	20	6.3	50/125	20/40	6	22000	53000	88	4GB7267-9DA05-0AG0 H2B	26720	3230	1905	4010
	20	11	50/125	28/60	6	22000	53000	88	4GB7267-9DA05-0AG0 H2T	26750	3385	1905	3730
	20	6.3	50/95	20/40	8	22000	55000	88	4GB7264-9KA05-0AG0 H2B	26170	3325	1905	3940
	20	11	50/95	28/60	8	22000	55000	88	4GB7264-9KA05-0AG0 H2T	26460	3455	1905	3700
	20	6.3	50/125	20/40	8	22000	55000	88	4GB7267-9KA05-0AG0 H2B	26530	3350	1905	4010
	20	11	50/125	28/60	8	22000	55000	88	4GB7267-9KA05-0AG0 H2T	26680	3455	1905	3730
	30	6.3	70/145	20/40	6	22000	55000	86	4GB7275-9DA05-0AG0 H2B	28930	3410	1905	3860
	30	11	70/145	28/60	6	22000	55000	86	4GB7275-9DA05-0AG0 H2T	29160	3575	1905	3650

1) Dimension drawing: page 14.

Connection System

Practice-oriented options for connection of the high-voltage and the low-voltage side are a distinguishing feature of the flexible connection philosophy of GEA FOL transformers.

Connection of the high-voltage side

In the standard design, the HV connection of the transformer is at the top coil connection, connection at the bottom is available as an option (Fig. 1). Screwed connection tubes are used for the delta connection. The transformer connection is made at the end of the connection tubes.

Connection of the high-voltage side using plug-type connectors

Connection of the HV side by using outside cone plug-type bushings is possible (see Fig. 2)

High-voltage tapplings

The HV tapplings allow matching to local network conditions. In deenergized state, the desired tapping can be selected by means of connection straps and screwed connections.

Connection of the low-voltage side

In the standard design, the LV connection of the transformer is also at the top; connection at the bottom is available as an option (Fig. 3).

If intermediate expansion links are employed, the LV side connection is protected against mechanical stress and transmission of structure-borne noise is drastically reduced.

Connection of earthing and short-circuiting devices

Either straight or angled spherical/earthing points, of diameter 20 mm or 25 mm, can be mounted at the connection tubes of the HV side and at the LV side at the conductor terminal face.

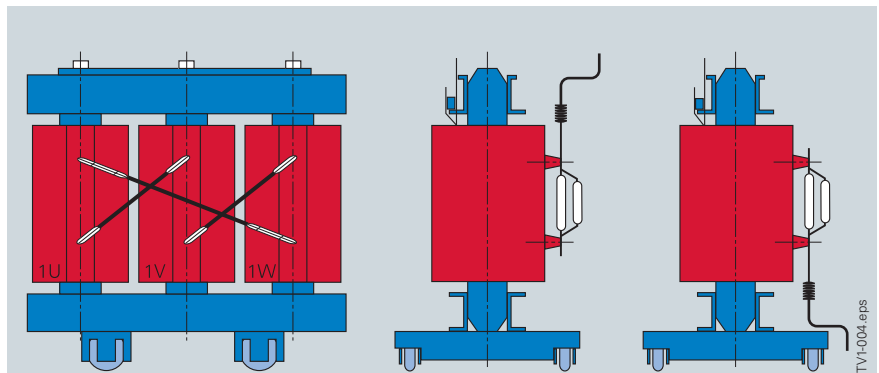

Fig. 1 Variable connection possibilities, e.g. at the delta-connected HV side

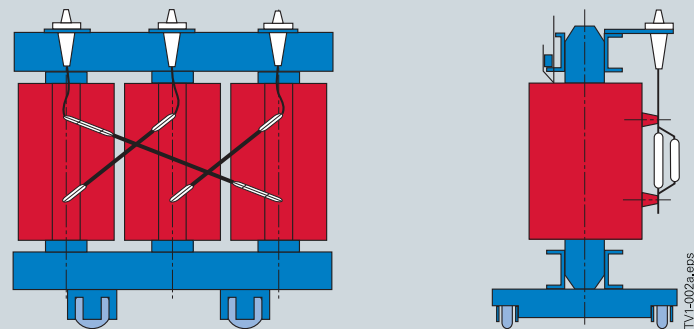

Fig. 2 Plug-type HV connectors

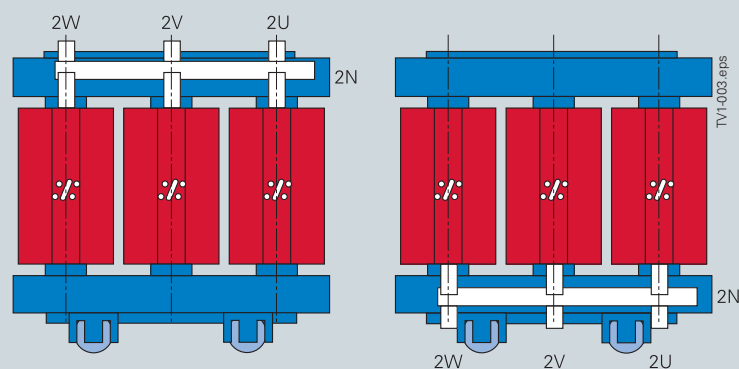

Fig. 3 LV connection system on GEA FOL transformers
left Fig.: Phase and neutral connection at top
right Fig.: Phase and neutral connection at bottom

Temperature Supervision, Forced-Air Cooling

Temperature supervision

Either PTC thermistor sensors, PT 100 resistance temperature detectors or a capillary tube thermometer can be employed for temperature supervision of GEAFOL transformers. The temperature of the LV windings is monitored and in addition in the case of converter transformers, also the core temperature is monitored. The most economical solution is monitoring by means of PTC thermistor sensors and tripping device without indication of the temperature. All GEAFOL transformers are provided with at least one PTC thermistor sensor circuit for tripping purposes.

Function

Temperature supervision by means of PTC thermistor sensors: In the case of three-phase transformers a system consists of 3 PTC thermistor sensors, connected in series, according to DIN – one sensor per phase – and a tripping device.

The PTC thermistor sensors function as resistances: When the response temperature of a sensor is reached, a step-change in resistance occurs and the contact in the tripping device is operated.

As soon as the temperature of the winding falls below the response temperature by approx. 6 K, the contact returns to its original position.

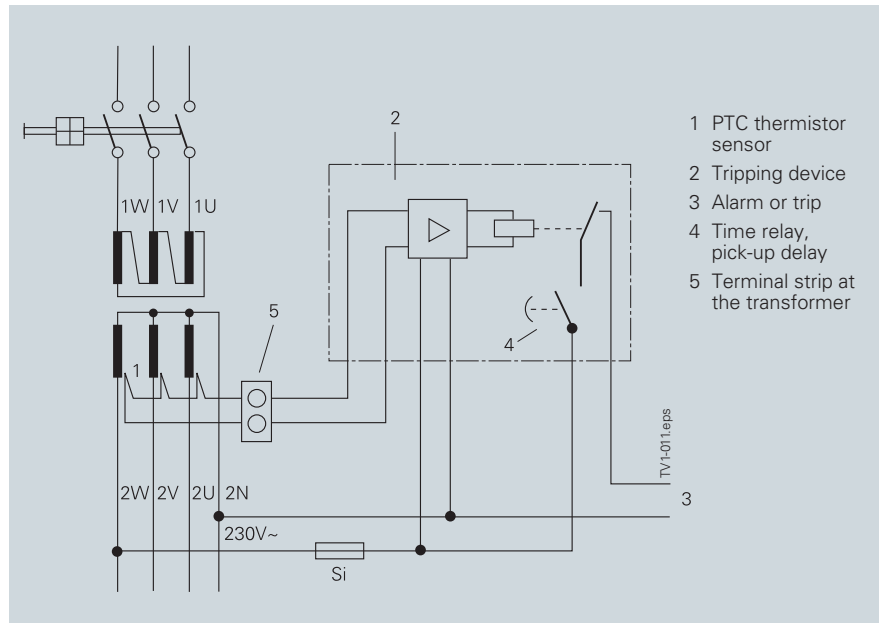

Typical circuit diagram for temperature supervision

Power supply for the tripping device from a system fed from the transformer to be protected

The supervision system is fail-safe. It thus provides protection against a wire-break in the sensor circuit.

When two sensor systems are employed for temperature supervision, one is connected to provide alarm signalling and the other tripping. The rated response temperatures of both systems differ by 20 K. A third system can, for example, be used for fan control.

If the control supply voltage for temperature supervision is taken directly from the secondary side of the transformer, a time relay is sometimes needed, depending on the unit. This time relay is used to bridge the time interval between energizing the transformer and pick-up of the relay in the tripping device.

The ambient temperature for the tripping device is limited to 55 °C. For this reason installation of the tripping device in medium or low-voltage distribution cabinets is to be recommended.

Additional forced-air cooling to increase the transformer output

GEAFOL transformers can be equipped with radial-flow fans to increase their output rating by up to 50 %. If the output is increased by e.g. 40 %, the load losses stated in the list will be doubled and the impedance voltage will be linearly increased by 40 %.

The fans are automatically switched on or off via thermistor sensors in the LV winding.



GEAFOL transformer with attached radial-flow fans

Standard Housings

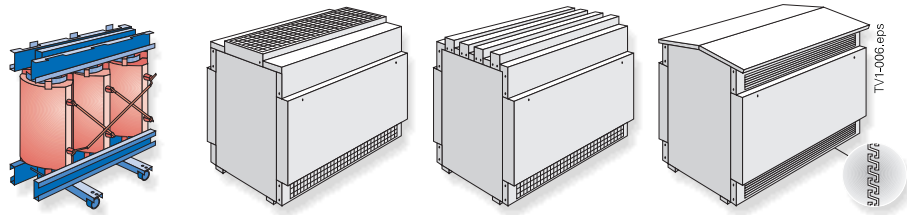

Installation	Indoors	Indoors	Indoors		Outdoors
Degree of protection	IP00	IP20	IP23	IP23D	IP23DW
14th position of the Order No.	A	B	C	D	E

Environmental conditions

Locked electrical locations ¹⁾	•	•	•	•	•
Electrical locations ¹⁾	–	•	•	•	•
Water up to 60 °C to ⊥	–	–	•	•	•
Snow	–	–	–	–	•
Direct sunlight	–	–	–	–	•
Salt-laden atmosphere	•	•	•	•	• Special paint
Corrosive chemical environment	•	•	•	•	• Special paint
Accidental contact	–	•	•	•	•
Foreign bodies > 12 mm dia.	–	•	•	•	•
Prod-proof ²⁾	–	–	On request	•	•

1) According to VDE 0100 Parts 200 and 731.

2) Test wire diameter 1 mm according to EN 60529.

Design of housing cover, degree of protection IP23 (indoor installation)

Drawing shows cross-section of ventilation slots in cover strips.

Photo: Cover strips are bent down at ends and fastened by bolting to walls.

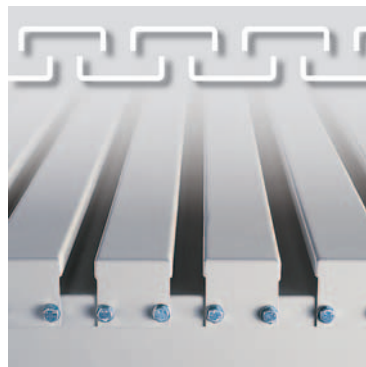

TV1P-001.tif

Prod-proof ventilation slots for additional safety.



TV1P-002.tif

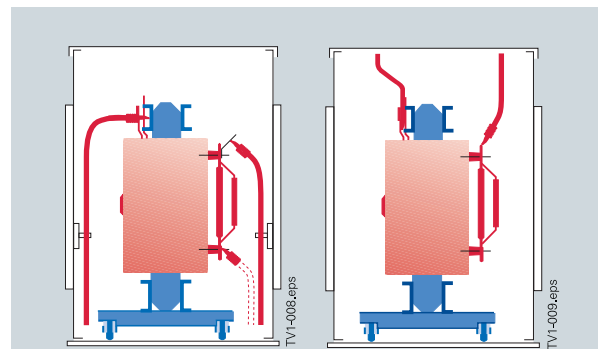

Variable connection techniques:
The cable can be brought in through the bottom, the cover or one of the sides.

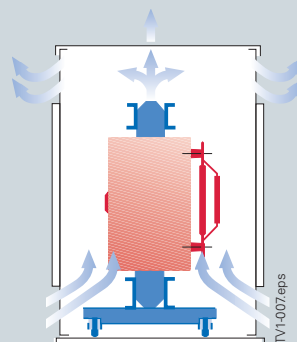

No reduction in output thanks to natural ventilation inside protective housing.

TV1-007.eps

Selection of Housings

Dimensions and weights

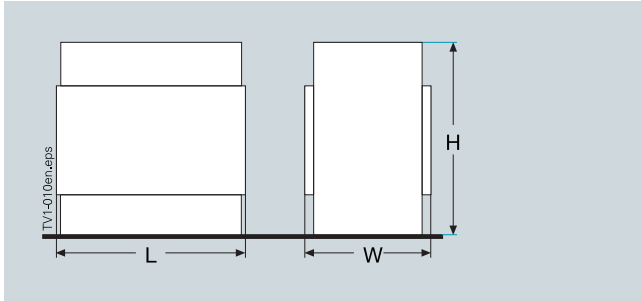

Indoor (degree of protection IP20)

Housing size	Maximum housing dimensions [mm]			Housing weight [kg]
	L	W	H	
1	1390	1010	1335	121
2	1860	1280	1535	177
3	1860	1280	1885	211
4	2120	1500	2120	252
5	2360	1500	2340	290

Indoor (degree of protection IP23 and IP23D)

Housing size	Maximum housing dimensions [mm]			Housing weight [kg]
	L	W	H	
1	1390	1010	1395	134
2	1860	1280	1595	207
3	1860	1280	1945	247
4	2120	1500	2225	302
5	2360	1500	2495	370

Outdoor (degree of protection IP23DW)

Housing size	Maximum housing dimensions [mm]			Housing weight [kg]
	L	W	H	
1	1440	1070	1540	153
2	1880	1320	1845	233
3	1880	1420	2245	267
4	2240	1540	2480	325
5	2380	1540	2950	392

Selection and ordering data *

Rated power S_r kVA	Rated voltage HV U_r kV	Order No.	Housing size
100	10	4GB50 44-3□A05-0□A2	1
	20	4GB50 64-3□A05-0□A2	2
160	10	4GB52 44-3□A05-0□A2	1
	20	4GB52 64-3□A05-0□A2	2
250	10	4GB54 44-3□A05-0□A2	2
	20	4GB54 64-3□A05-0□A2	2
(315) ¹⁾	10	4GB55 44-3□A05-0□A2	2
	20	4GB55 64-3□A05-0□A2	2
400	10	4GB56 44-3□A05-0□A2	2
	20	4GB56 64-3□A05-0□A2	2
(500) ¹⁾	10	4GB57 44-3□A05-0□A0	2
	20	4GB57 64-3□A05-0□A0	2
630	10	4GB58 44-3CA05-0□A0	2
	20	4GB58 64-3CA05-0□A0	2
	10	4GB58 44-3DA05-0□A0	2
	20	4GB58 64-3DA05-0□A0	2
	10	4GB58 44-3GA05-0□A0	3
	20	4GB58 64-3GA05-0□A0	2
	10	4GB58 44-3HA05-0□A0	2
	20	4GB58 64-3HA05-0□A0	2
(800) ¹⁾	10	4GB59 44-3□A05-0□A0	3
	20	4GB59 64-3□A05-0□A0	3
1000	10	4GB60 44-3CA05-0□A0	3
	20	4GB60 64-3CA05-0□A0	3
	10	4GB60 44-3DA05-0□A0	3
	20	4GB60 64-3DA05-0□A0	3
	10	4GB60 44-3GA05-0□A0	3
	20	4GB60 64-3GA05-0□A0	4
	10	4GB60 44-3HA05-0□A0	3
	20	4GB60 64-3HA05-0□A0	4
(1250) ¹⁾	10	4GB61 44-3□A05-0□A0	4
	20	4GB61 64-3□A05-0□A0	4
1600	10	4GB62 44-3□A05-0□A0	4
	20	4GB62 64-3□A05-0□A0	4
(2000) ¹⁾	10	4GB63 44-3□A05-0□A0	5
	20	4GB63 64-3□A05-0□A0	5
2500	10	4GB64 44-3DA05-0□A0	5
	20	4GB64 64-3DA05-0□A0	5
	10	4GB64 44-3HA05-0□A0	5 ²⁾
	20	4GB64 64-3HA05-0□A0	5 ³⁾
> 2500	Standard housings on request.		

*) Other versions and special equipment available on request.

1) Ratings in brackets are not standardized.

2) IP20: Height + 100 mm.

3) IP20/IP23/IP23D/IP23DW: Width and height + 100 mm

Special Housings, Notes

Dimensions

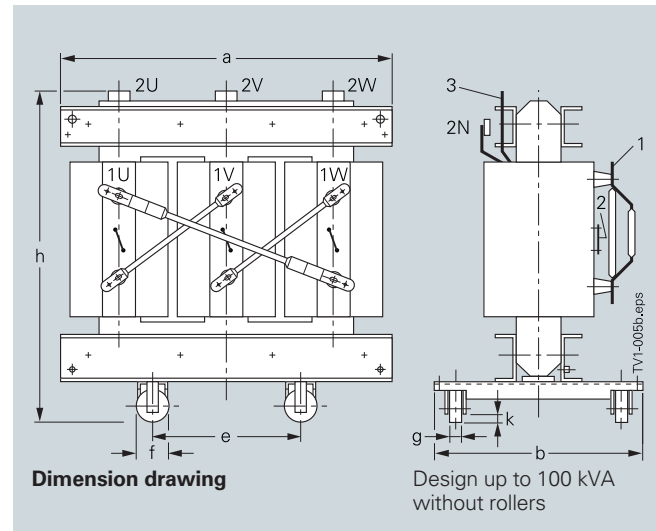

- 1 High-voltage terminals
- 2 High-voltage tappings on HV side
- 3 Low-voltage terminals

Dimensions a, b and h, see pages 5 to 9

In addition to the standard housings, we also supply housings with framework construction and doors, which can also be fitted with roof fans. These housing types can be installed in combination with low and medium-voltage cabinets.

Please contact us for more information.

Notes:

The technical data, dimensions and weights are subject to change unless otherwise stated on the individual pages of this catalog.

The illustrations are for reference only.

All product designations used are trademarks or product names of Siemens AG or of other suppliers.

All dimensions in this catalog are given in mm.

The information in this document contains general descriptions of the technical options available, which do not always have to be present in individual cases. The required features should therefore be specified in each individual case at the time of closing the contract.

Truck dimensions

Rated power S_r in kVA	Dimensions			
	e	f	g	k
50 to 250	520	125	40	45
315 to 800	670	125	40	45
1000 to 1600	820	160	50	55
2000 to 5000	1070	200	70	65
> 5000	1505	250	130	50

Hole dimensions for LV connections

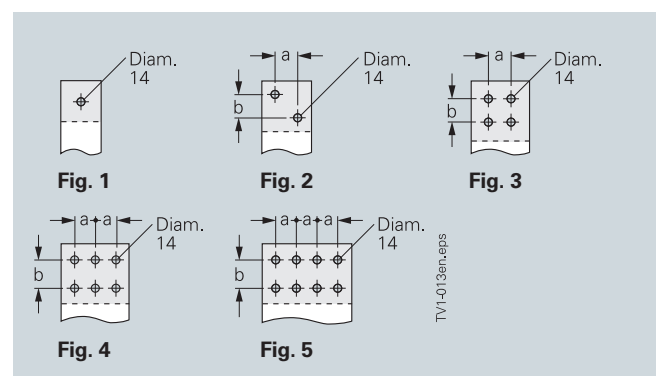

Rated power S_r in kVA	Figure	Dimensions	
		a	b
w 100	1	—	—
125 to 160	1	—	—
200 to 630	2	26	26
800 to 1250	3	60	40
1600	4	40	40
2000	4	50	40
2500	4	60	40
3150	5	60	40

Siemens AG

Power Transmission and Distribution
Transformers Division
Transformatorwerk Kirchheim
Hegelstraße 20
73230 Kirchheim/Teck
Germany
Tel.: +49 (0) 7021 508-0
Fax: +49 (0) 7021 508-495

Siemens Transformatórkft.
1214 Budapest
II.Rákóczi Ferec u. 189.
Hungary
Tel.: +36 (1) 278 53 00
Fax: +36 (1) 278 53 35

www.siemens.com/energy

For questions concerning
Power Transmission and Distribution:
You can contact our Customer Support
Center 24 hours a day, 365 days a year.
Tel.: +49 180/524 70 00
Fax: +49 180/524 24 71
(Charges depending on provider)
E-Mail: support.energy@siemens.com
www.siemens.com/energy-support

Subject to change without notice
Order No.:
E50001-K7101-A101-A6-7600
Printed in Germany
Dispo 19201
KG 10.07 5.0 16 En
102691 6101/6486